

1,000 HP (741 KW) MORGAN USED SPEED INCREASER / GEARBOX

MANUFACTURER:	MORGAN	
HP RATING:	1000	(741 KW)
INPUT RPM:	600	
RATIO:	2.25:1	
REDUCTION:	SINGLE	
SERVICE FACTOR:	1.0	
TYPE:	PARALLEL	
GEAR TYPE:	HELICAL	
BEARING TYPE:	AF	
WEIGHT:	10,120 LBS.	(4,590 KG)

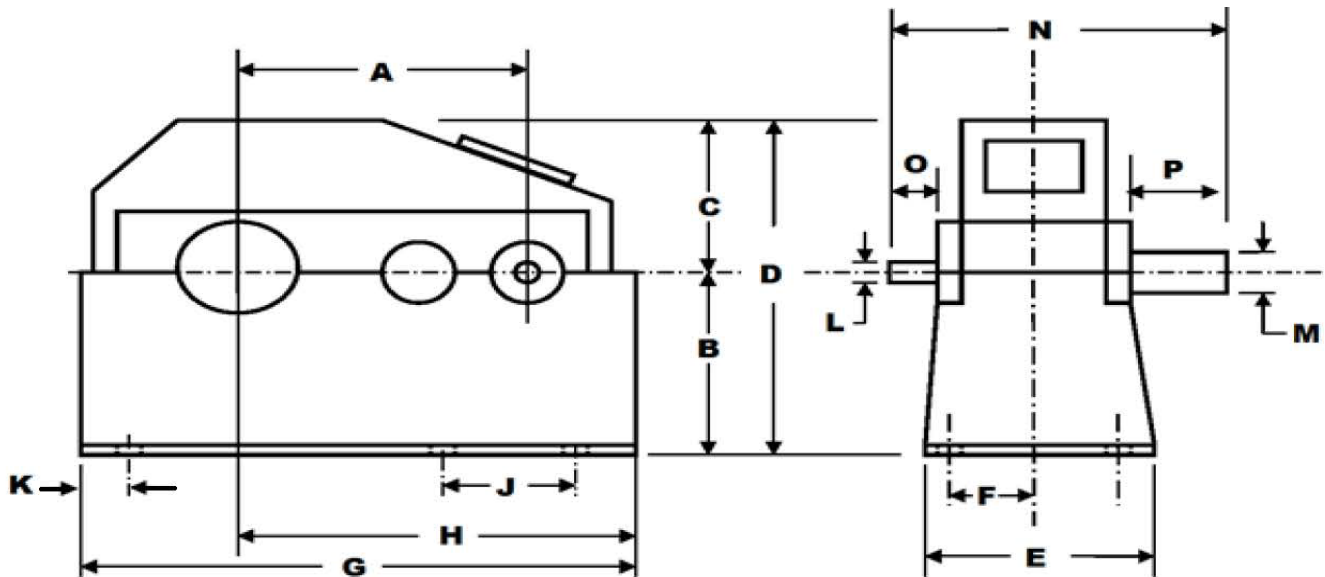

A=27.75"	E=28"	J=55"	N=52"
B=22"	F=11.5"	K=10"	O=10"
C=21.75"	G=72"	L=4.75"	P=10"
D=43"	H=48"	M=1.75"	

INVENTORY ID: 107484-000-00

CASEYUSA®

Revised 2/26/19

Page 1 of 1

CASEY

275 Kappa Drive, Pittsburgh, PA 15238

Ph: (800) 882-7000 • (412) 963-1111

Fax: (412) 963-0378

E-mail: mechanicalsales@caseyusa.com

Web: www.caseyusa.com