

# 14,600 HP (10,820 KW) FARRELL 51-3613-6 PARALLEL USED GEAR INCREASER / GEARBOX

MANUFACTURER: FARRELL  
 AGE: 1961  
 MODEL NO.: 51-3613-6  
 SERIAL NO.: 60-BD-3327  
 HP RATING: 14,600  
 INPUT RPM: 875  
 RATIO: 1:2.4706  
 REDUCTION: SINGLE  
 SERVICE FACTOR: 1.0  
 TYPE: PARALLEL  
 GEAR TYPE: HERRINGBONE  
 BEARING TYPE: ROLLER  
 WEIGHT: 26,500 LBS.

(10,820,KW)

(12,024 KG)

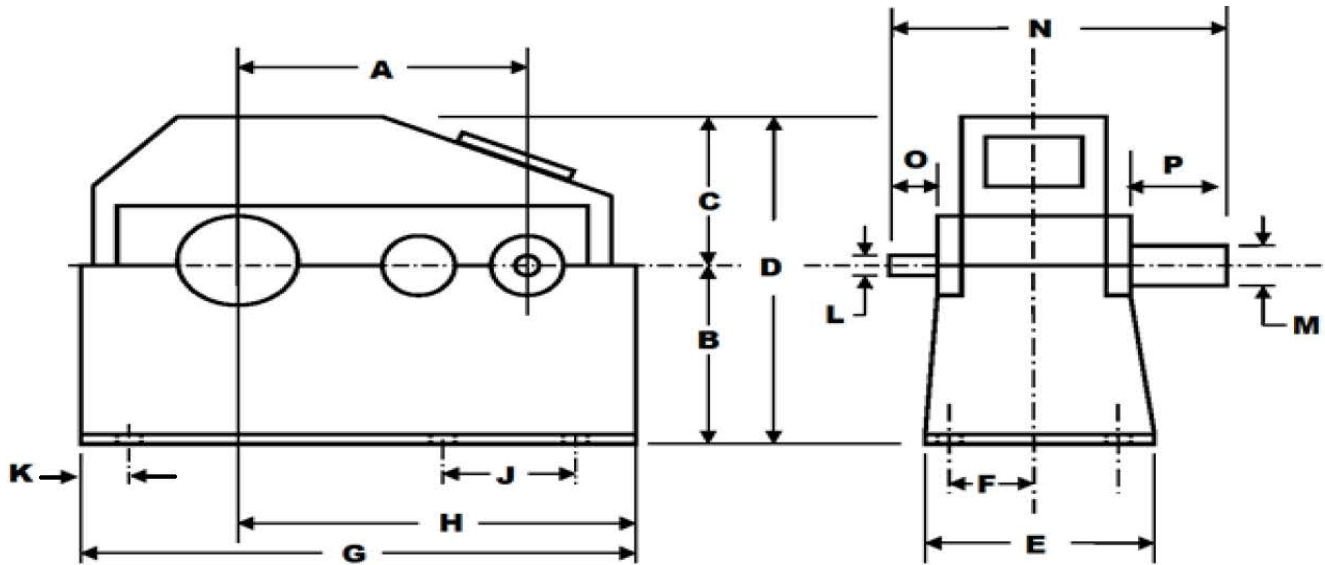

A=36"	E=42"	J=23.5"	N=65"
B=39.5"	F=18.75"	K=2.5"	O=11"
C=34.5"	G=97.5"	L=6.5"	P=14.5"
D=74"	H=59"	M=9"	

INVENTORY ID: 107317-000-00

**CASEYUSA®**

Revised 2/26/19

Page 1 of 1

**CASEY**

275 Kappa Drive, Pittsburgh, PA 15238

Ph: (800) 882-7000 • (412) 963-1111

Fax: (412) 963-0378

E-mail: [mechanicalsales@caseyusa.com](mailto:mechanicalsales@caseyusa.com)

Web: [www.caseyusa.com](http://www.caseyusa.com)